



EstesRockets.com

MINI ARCAS

2441

AGES
10+



Skill Level

ADVANCED

MODEL ROCKET INSTRUCTIONS

KEEP FOR FUTURE REFERENCE

IMPORTANT: Please record date found on decal and keep for future reference. _____

READ ALL INSTRUCTIONS. Make sure you have all parts and supplies. Test fit all parts before applying glue. Refer to your glue manufacturer's dry times during build.

SUPPLIES

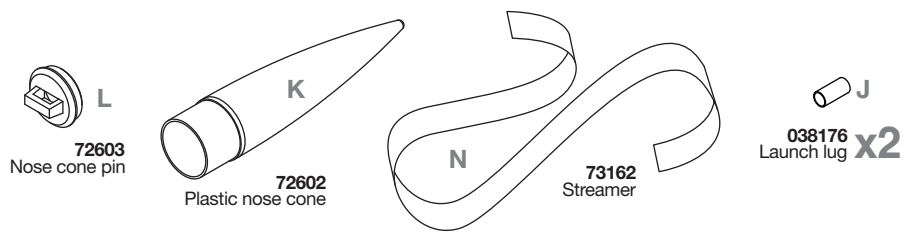
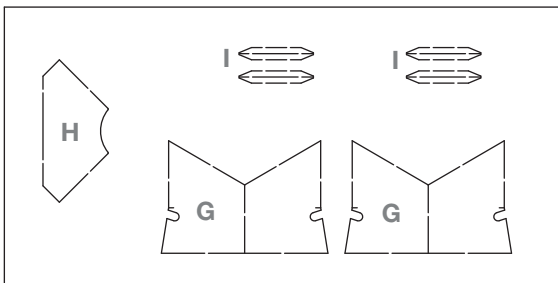

090051-2441
Last cut balsa

030222-4
Yellow engine
block

30162-2
Green ring **x2**

31787
Engine tube

090057-2441
Printed index stock

85863
Body tube

38367
Shock cord

ATLANTIC RESEARCH CORP.

ARCAS



090001-2441
Waterslide decal

35002
Yellow spacer
tube

PREPARE TAIL CONE

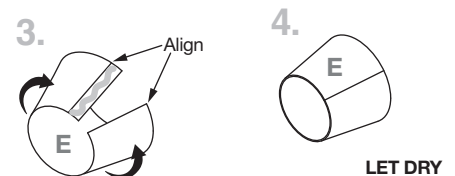
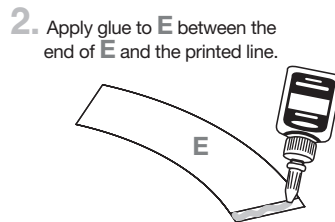

LET DRY

PREPARE FIN DETAIL

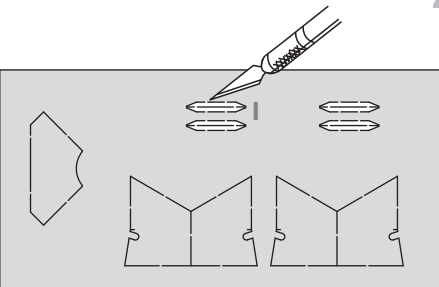

2. Using a small sanding bar, bevel both ends of I.

3. Using a sanding bar, round one edge of I.

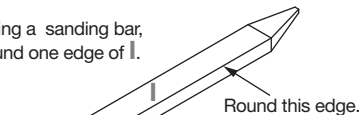
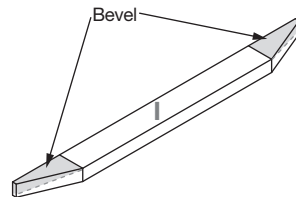

5. Use **Template A** below to measure and mark a pencil line in the center of I.



6. Using a hobby knife, cut part way through the center line of I just enough to bend it down.

7.





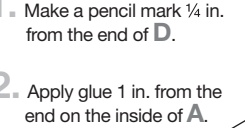
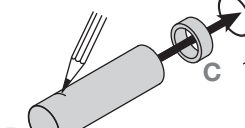
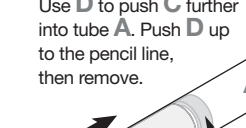
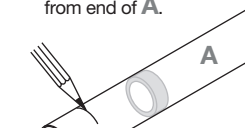

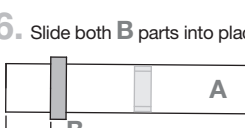
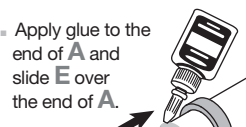
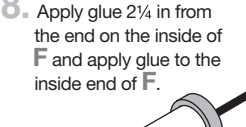
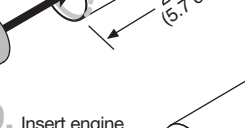
Template A.

NOTE:
Repeat steps 2-7 for all I pieces.

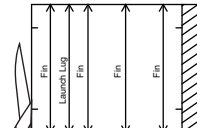
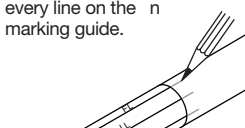
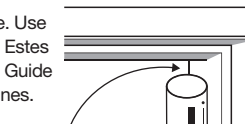
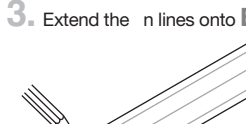
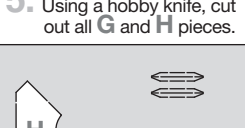
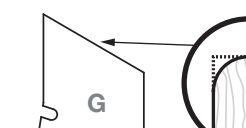
ASSEMBLE ENGINE MOUNT

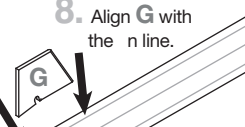
1. Make a pencil mark $\frac{1}{4}$ in. from the end of **D**.

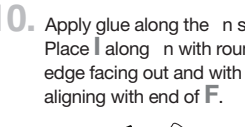
 2. Apply glue 1 in. from the end on the inside of **A**.

 3. Insert **C** into the end of **A**. Use **D** to push **C** further into tube **A**. Push **D** up to the pencil line, then remove.

 4. Make a pencil mark $\frac{1}{2}$ in. from end of **A**.

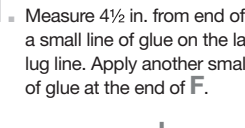
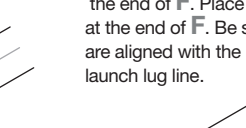
 5. Apply glue just past the pencil mark on **A** and on the opposite end of **A**.

 6. Slide both **B** parts into place as shown below.

 7. Apply glue to the end of **A** and slide **E** over the end of **A**.

 8. Apply glue $2\frac{1}{4}$ in. from the end on the inside of **F** and apply glue to the inside end of **F**.

 9. Insert engine mount **A** into tube **F**.

- LET DRY**

FIN INSTALLATION

1. Cut out the full size fin marking guide on page 3.

 2. Wrap the fin marking guide around tube **F** and secure it with clear tape. Make pencil marks on tube **F** for every line on the fin marking guide.

 3. Remove guide. Use door frame or Estes Tube Marking Guide to extend all lines.

 4. Extend the fin lines onto **E**.

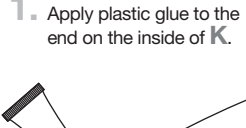
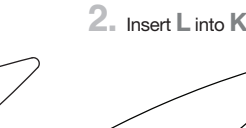
 5. Using a hobby knife, cut out all **G** and **H** pieces.

 6. Round the leading edge of all the **G**s.

 7. Apply glue to the inside edge of **G**.

 8. Align **G** with the fin line.

 9. Repeat for all four fins, using **H** to assist with alignment and spacing.

 10. Apply glue along the fin seam. Place **I** along fin with rounded edge facing out and with bend aligning with end of **F**.

 11. Repeat for both sides of every fin.

- LET DRY**
- NOTE:**
Use fin alignment guide on page 3 to ensure proper fin alignment.

LAUNCH LUG ATTACHMENT

1. Measure $4\frac{1}{2}$ in. from end of **F** apply a small line of glue on the launch lug line. Apply another small line of glue at the end of **F**.

 2. Place launch lugs **J** $4\frac{1}{2}$ in. from the end of **F**. Place the other at the end of **F**. Be sure both are aligned with the launch lug line.

- LET DRY**

ASSEMBLE NOSE CONE

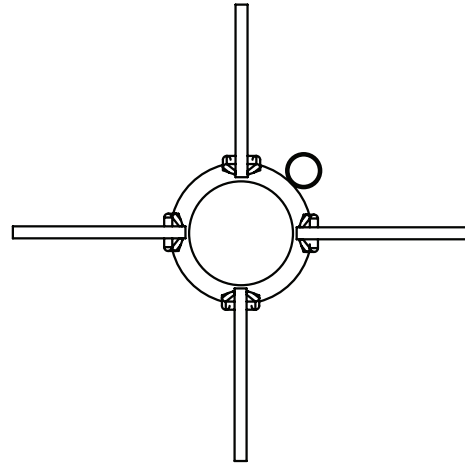
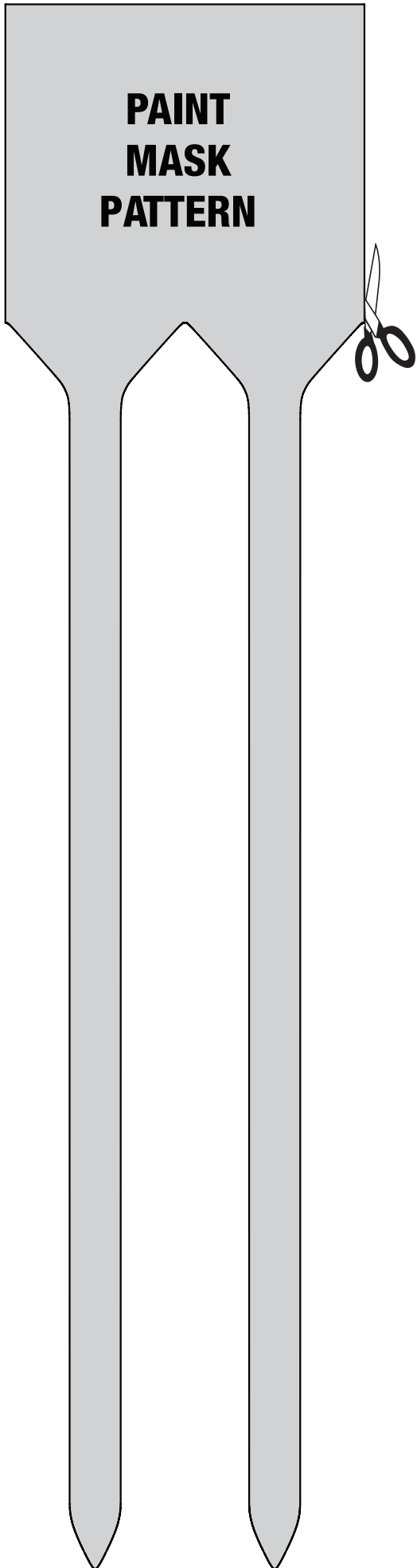
1. Apply plastic glue to the end on the inside of **K**.

 2. Insert **L** into **K**.

- LET DRY**

**PAIN
T MASK
PATTERN**

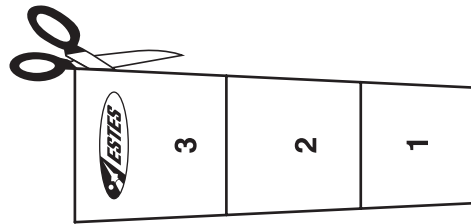

FIN ALIGNMENT GUIDE



SHOCK CORD ANCHOR

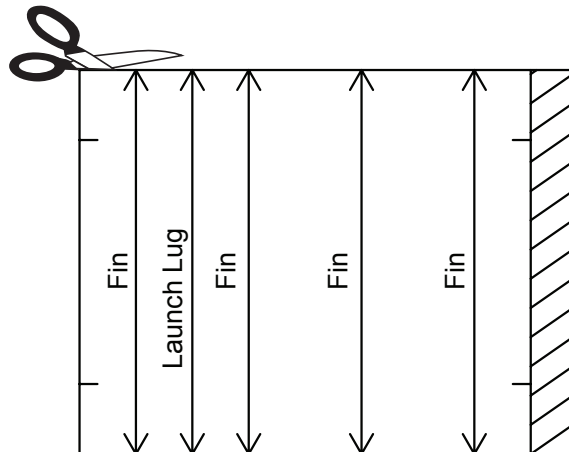

FULL SIZE FIN MARKING GUIDE

PAINTING & DECAL

1. Spray rocket with white primer, let dry, and sand. Repeat until rocket is smooth.
2. Spray entire rocket with white paint and let dry. (Follow paint manufactures recommended drying time)
3. Cut out paint mask pattern.
4. Wrap paint mask around tube and tape upper portion together.
5. Trace around mask edge lightly with a pencil.
6. Remove mask.
7. Use painter's tape to mask the outside perimeter of pencil line.
8. Completely mask off the rest of the bottom of the rocket.
9. Spray unmasked part of rocket with red paint and let dry.
10. Mask bottom shoulder of nose cone with painter's tape.
11. Spray nose cone with red paint and let dry.
12. Apply decals.

CAUTION:

See manufacturer's warnings and instructions before using spray finishing products.

NOTE:

Please refer to packaging for suggested paint scheme and/or decal placement.

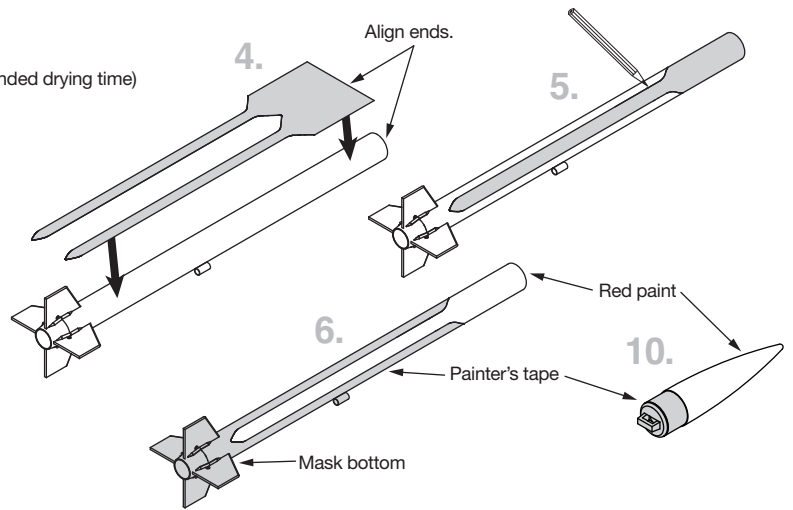

INSTALL RECOVERY SYSTEM

1. Cut out the shock cord anchor on page 3.
2. Apply glue to shock cord anchor.
3. Hold until set.
4. Hold until set.
5. Apply glue to shock cord mount.
6. Glue shock cord mount to inside of body tube. 1" (2.5 cm)
7. Hold until set.
8. Double knot.
9. Clear tape.
10. Clear tape.
11. 2nd piece of clear tape.

PREPARE FLIGHT RECOVERY

1. Push recovery wadding down towards end of the body tube. 2-3 SQUARES ESTES® RECOVERY WADDING
2. Recovery wadding and parachute must slide easily into body tube. If too tight, redo.

IF NOSE CONE FIT IS...



PREPARE ENGINE

1. Use one each. PLUG, STARTER, ENGINE
2. ENGINE
3. STARTER
4. PLUG
5. TIP MUST TOUCH PROPELLANT!
6. TIP MUST TOUCH PROPELLANT!

NOTE:

Engine must have a snug fit inside engine mount. Wrap masking tape around engine until a snug fit is achieved.

NOTE:
Always keep the key **OUT** until final countdown.

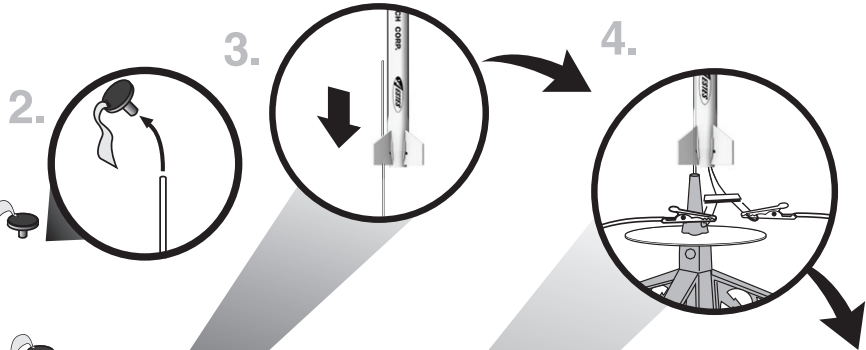
5. Fully extend your launch controller wire before launching.



16.4 ft. (5 m)

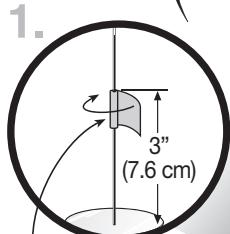

MASKING TAPE

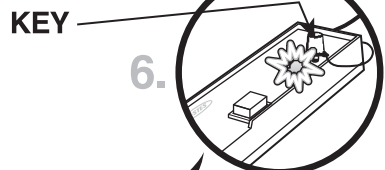

KEY

Insert key, push down hard. Bulb will light.

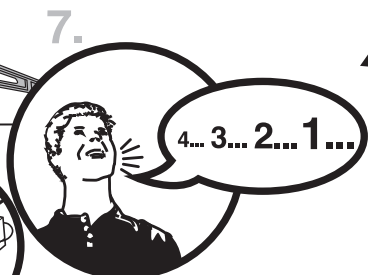

While holding key down **FIRMLY**, press launch button until **LIFTOFF!**

NOTE:
Estimated weight: 0.75 oz. (21.1 g)

- ESTES® LAUNCH SUPPLIES NEEDED (Sold Separately)**
- Porta-Pad® II Launch Pad
 - Electron Beam® Launch Controller
 - Recovery Wadding
 - Starters (with engines)
 - Plugs (with engines)
 - Estes® Engines: A3-4T (right), 1/2A3-2T, A3-6T, A10-3T

PRECAUTIONS



NAR SAFETY CODE



NO DRY GRASS OR WEEDS

PRE-LAUNCH CHECK For safety, never launch a damaged rocket. Check the rocket's body, nose cone and fins. Also, check the engine mount, recovery system and launch lug(s). Repair any damage before launching the rocket.

FLYING YOUR ROCKET Choose a large field (500 ft. [152 m] square) free of dry weeds and brown grass. The larger the launch area, the better your chance of recovering your rocket. Launch only with little or no wind and good visibility. Always follow the National Association of Rocketry (NAR) SAFETY CODE (enclosed).

MISFIRES TAKE THE KEY OUT OF THE CONTROLLER. WAIT ONE MINUTE BEFORE GOING NEAR THE ROCKET. Disconnect the micro-clips and remove the engine. Take the plug and starter out of the engine. A burned starter means the starter tip was not touching engine propellant. Install a new starter; be sure the tip is touching propellant inside the engine. Push the plug in place. Repeat steps under Countdown and Launch.

