



EstesRockets.co

CADET™

2021



MODEL ROCKET INSTRUCTIONS

KEEP FOR FUTURE REFERENCE

IMPORTANT: Please record date found on decal and keep for future reference. _____

READ ALL INSTRUCTIONS. Make sure you have all parts and supplies. Test fit all parts before applying glue. Product color and shape may vary.

SUPPLIES



SCISSORS



PENCIL



RULER



YELLOW GLUE



HOBBY KNIFE



MASKING TAPE



PLASTIC CEMENT

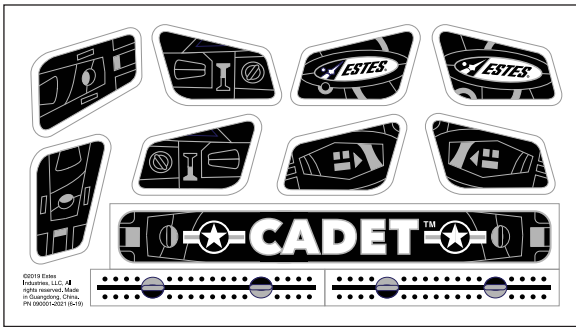

090001-2021
Self-stick decal

J 072675
Launch lug rings

G 046002
Body tube

H 071026
Nose cone

Not used

F 030165-2
Green adapter ring

K 038367
Shock cord

A 030408
Engine mount tube

D 030162-2
Green engine block ring

B 035021
Engine hook

E 072678
Fin unit

C 030170-3
Black engine hook
retainer ring

L 035801
Parachute

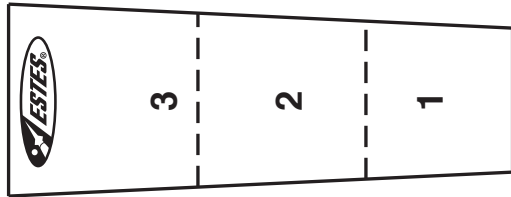

Shock cord mount

(Make a copy if you want to keep instructions.)

ASSEMBLE ENGINE MOUNT

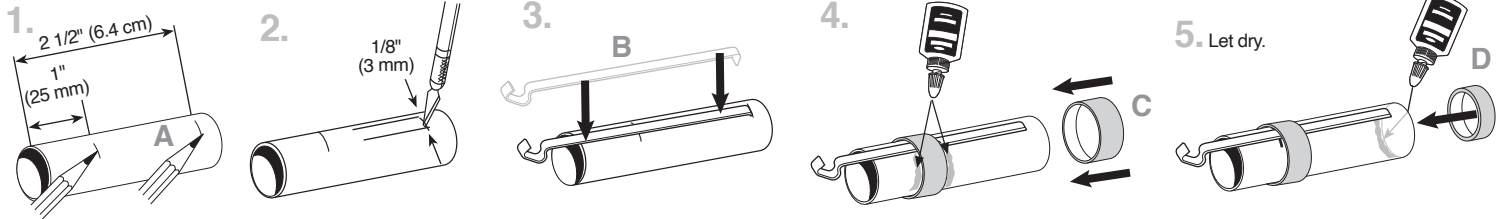

INSTALL ENGINE MOUNT

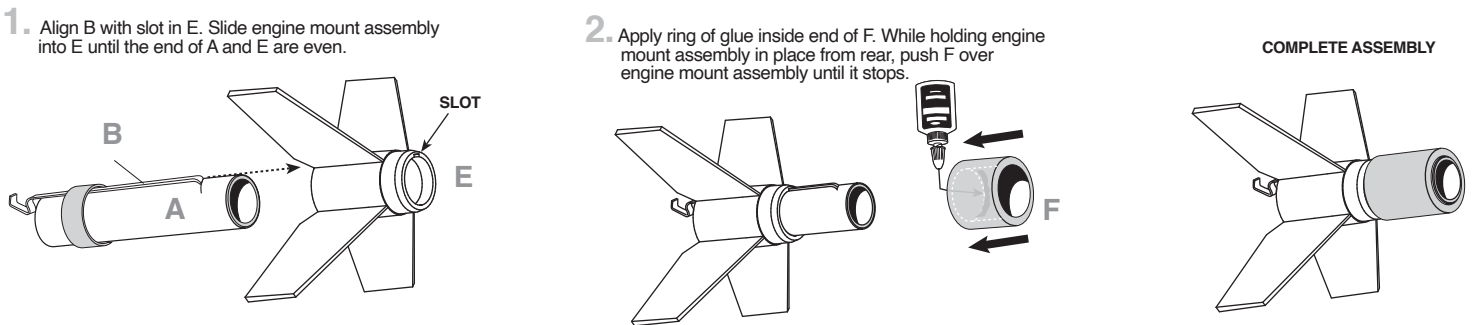

ATTACH BODY TUBE

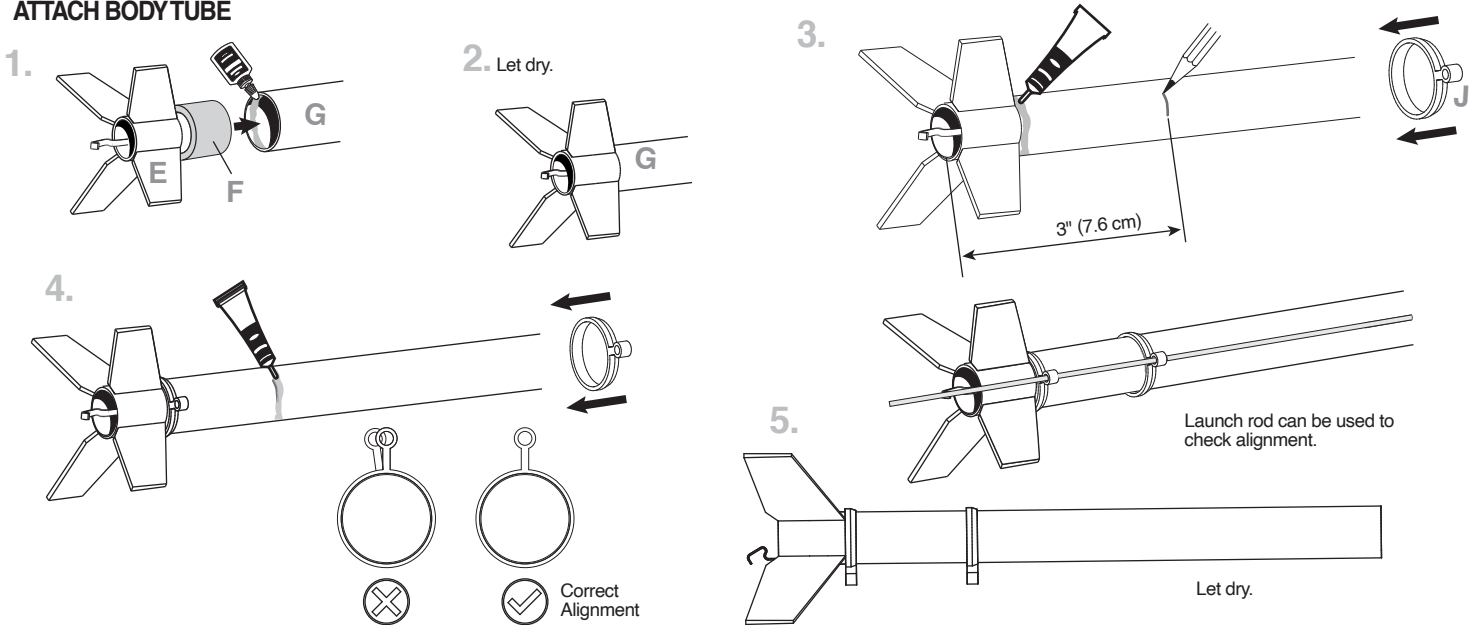

ATTACH SHOCK CORD

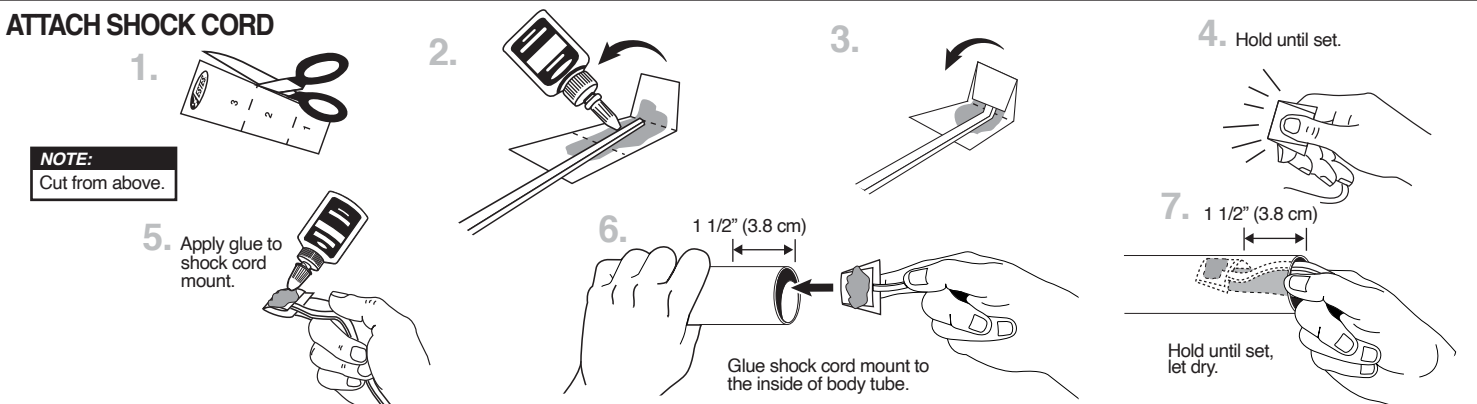

PREPARE NOSE CONE

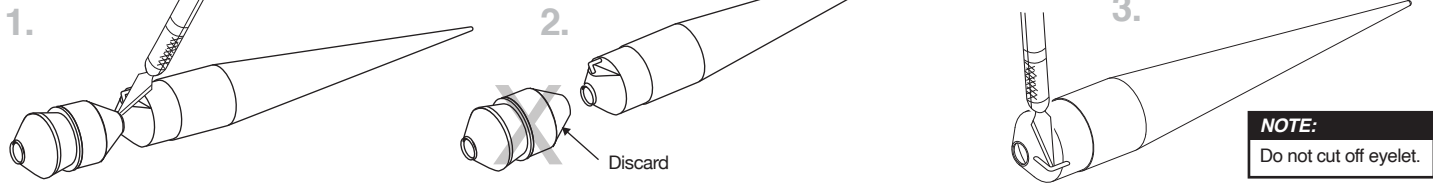

PREPARE RECOVERY SYSTEM

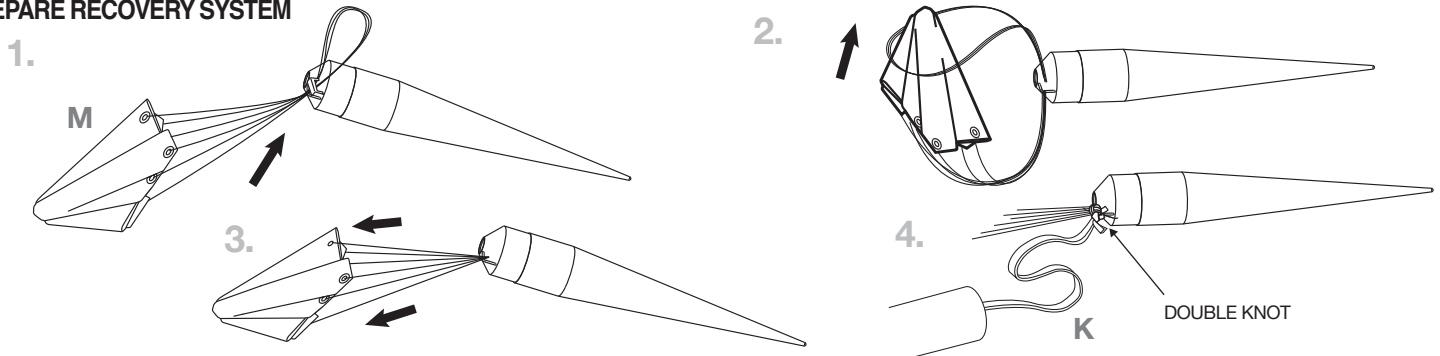

PREPARE ENGINE

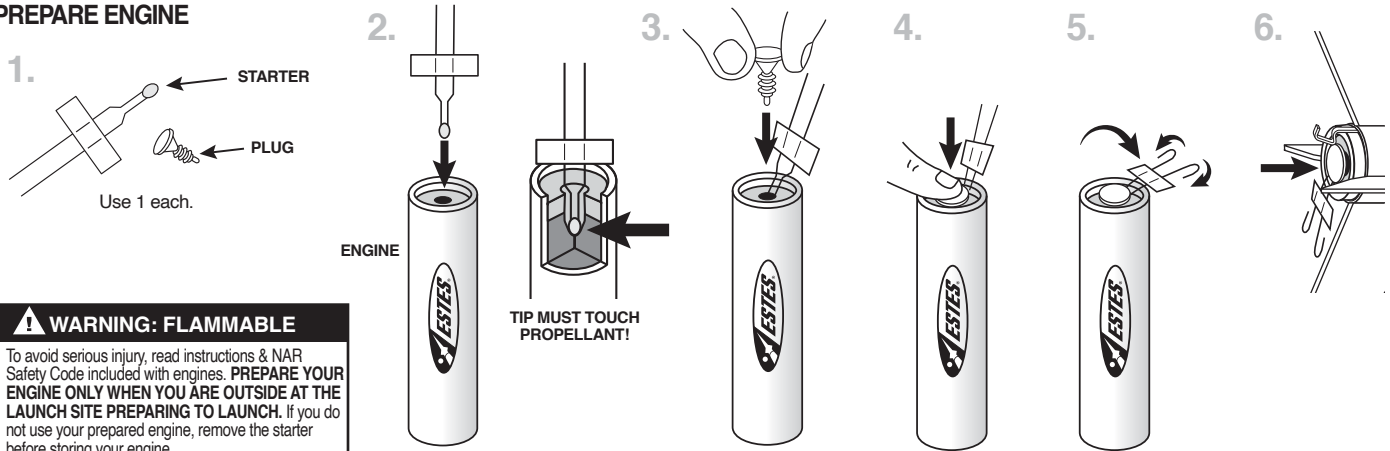

! WARNING: FLAMMABLE

To avoid serious injury, read instructions & NAR Safety Code included with engines. **PREPARE YOUR ENGINE ONLY WHEN YOU ARE OUTSIDE AT THE LAUNCH SITE PREPARING TO LAUNCH.** If you do not use your prepared engine, remove the starter before storing your engine.

PREPARE FLIGHT RECOVERY

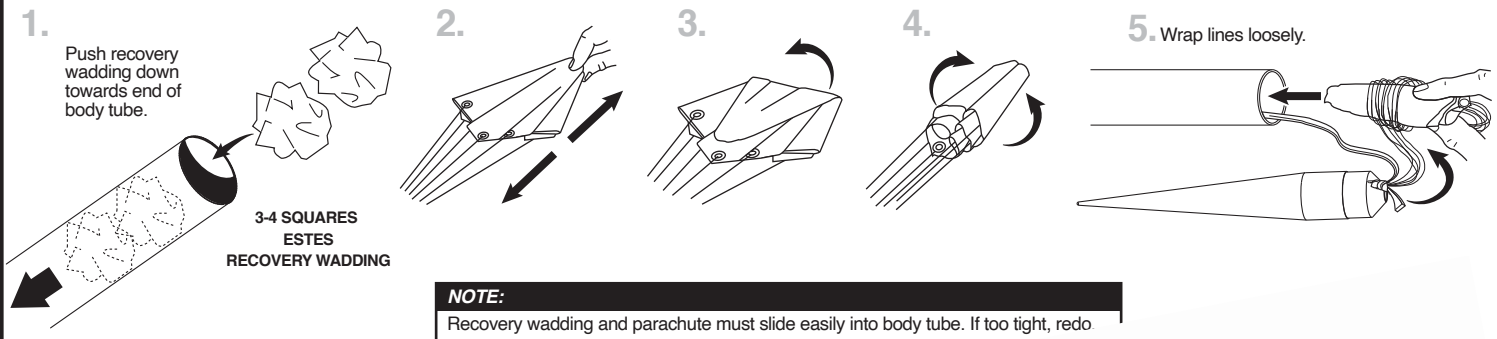

APPLY DECALS

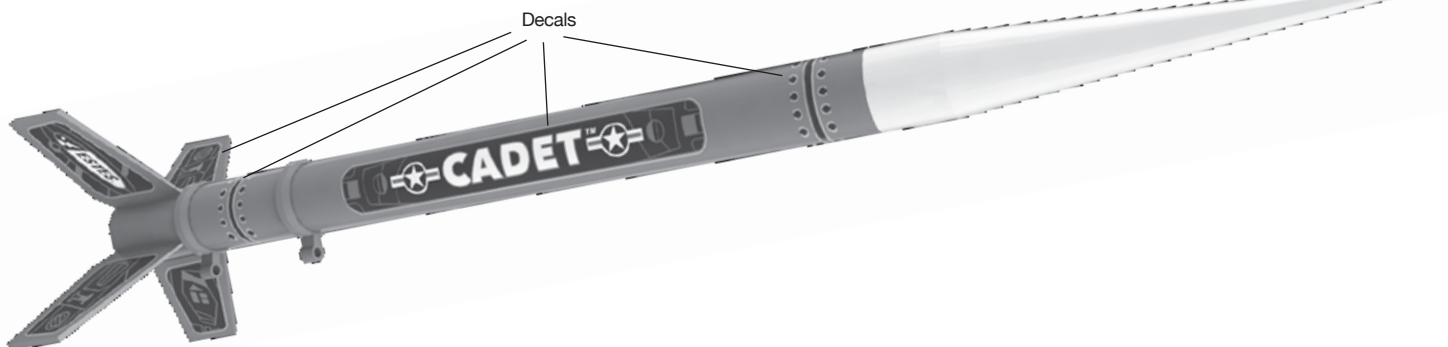

NOTE:
Key always out until final countdown!

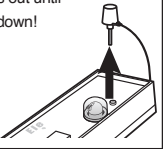

- ESTES® LAUNCH SUPPLIES NEEDED (Sold Separately)**
- Launch Pad
 - Launch Controller
 - Starters (with engines)
 - Plugs (with engines)
 - Recovery Wadding
 - Estes® Engines:
A8-3 (first launch), B4-4, B6-4, C6-5, C6-7

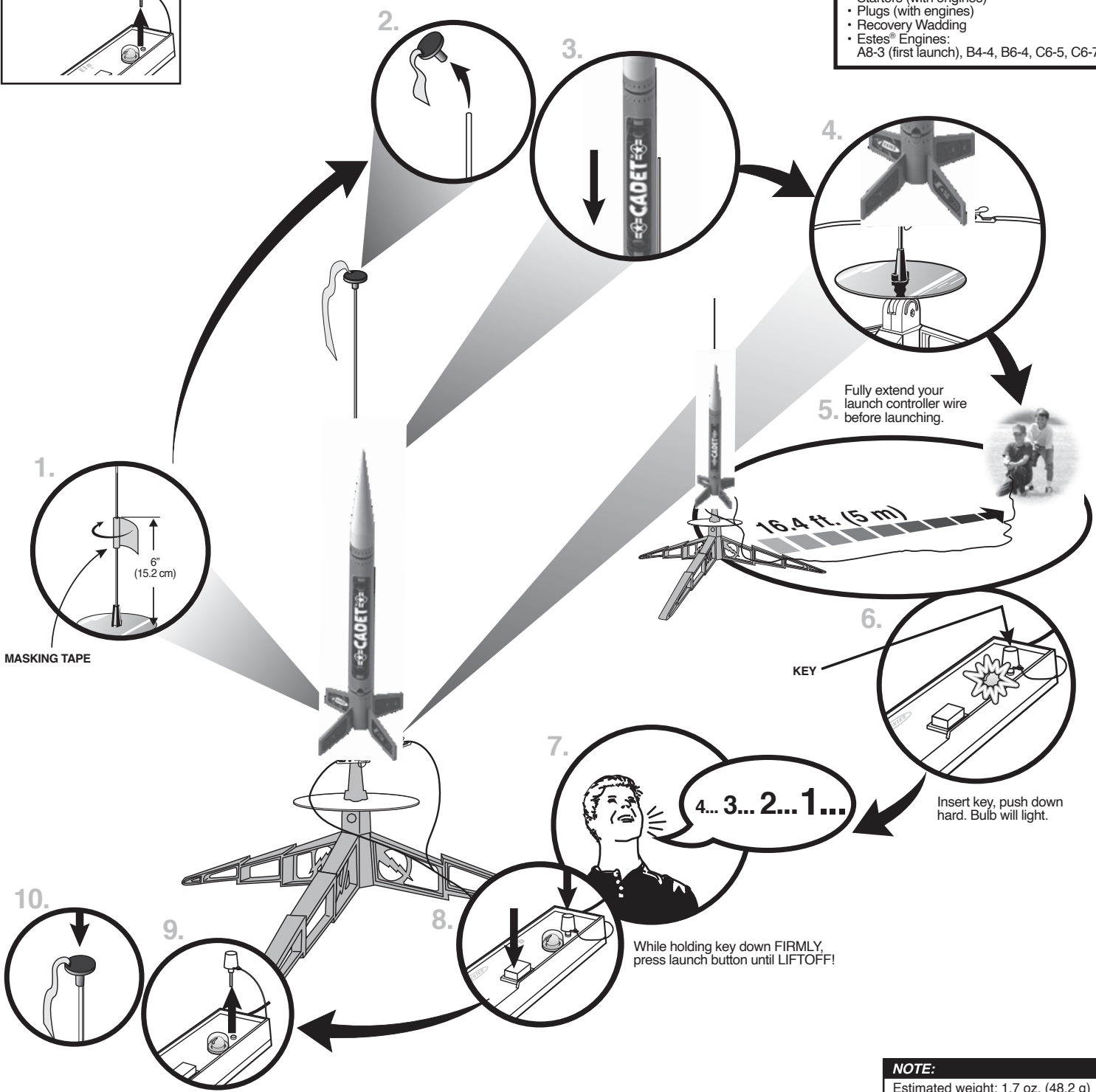

NOTE:
Estimated weight: 1.7 oz. (48.2 g)

PRECAUTIONS

NAR SAFETY CODE



NO DRY GRASS OR WEEDS

PRE-LAUNCH CHECK For safety, never launch a damaged rocket. Check the rocket's body, nose cone and fins. Also, check the engine mount, recovery system and launch lug(s). Repair any damage before launching the rocket.

FLYING YOUR ROCKET Choose a large field (500 ft [152 m] square) free of dry weeds and brown grass. The larger the launch area, the better your chance of recovering your rocket. Football fields and playgrounds are great. Launch only with little or no wind and good visibility. Always follow the National Association of Rocketry (NAR) SAFETY CODE (enclosed).

MISFIRES TAKE THE KEY OUT OF THE CONTROLLER. WAIT ONE MINUTE BEFORE GOING NEAR THE ROCKET! Disconnect the starter clips and remove the engine. Take the plug and starter out of the engine. If the starter has burned, it worked but did not ignite the engine because it was not touching the propellant inside the engine. Put a new starter all the way inside the engine without bending it. Push the plug in place. Repeat the steps under Countdown and Launch.